

**New!**

# canplas®

PRICE LIST  
C51-101

## RUBBER ROOF FLASHINGS

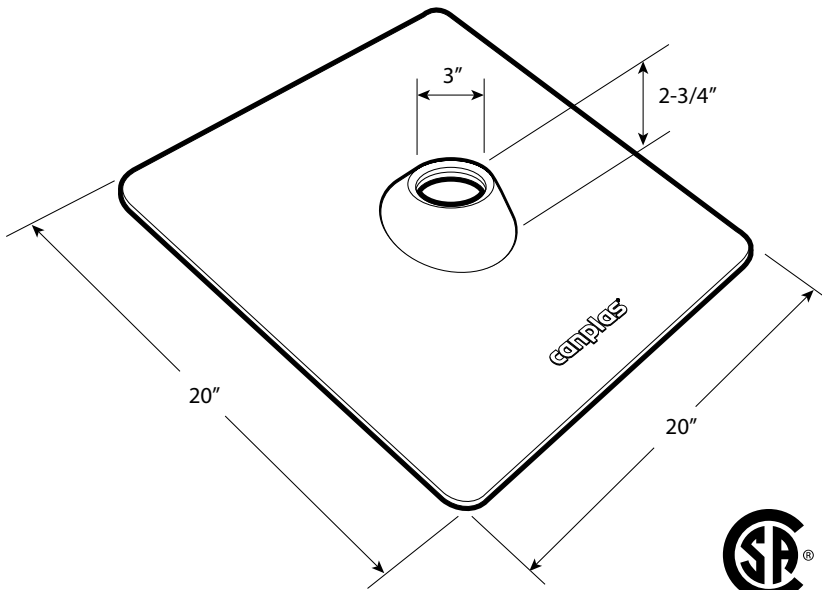

# Rolls easily, stays put!

## The New PermOseal® Rubber Roof Flashing

Advanced additives protect the flashing from extreme weather, while remaining flexible and watertight for years to come. Approved to CSA B272

- UV stabilized
- PermOseal® profile seals around vent pipe
- 20" x 20" size ensures a leak free installation
- Suitable for 2-12 to 12-12 roof pitches
- For use with 3" ABS, PVC, copper or cast iron vent pipe
- Suitable for cold weather applications

PART #	DESCRIPTION	CTN. QTY.	SKID QTY.	PRICE	Weight (Kgs)	Carton Barcode
513103	3" Rubber Roof Flashing 20" x 20"	12	360	\$12.50	0.598	10662671510010

### DECEMBER 15, 2009

www.canplasplumbing.com 1-800-461-5300

## TERMS AND CONDITIONS OF SALE

### TERMS

Cash discount 2% 15 days, net 30. The cash discount is allowed on merchandise only. Prices are subject to change and each order will be priced on the basis of prices in effect at the time of order. All orders are subject to approval of our office in Ontario, Canada. Possession of this price list does not necessarily constitute an offer by the Company to sell to the holder on the basis of the terms described hereon.

### MINIMUM ORDER

\$250.00 net.

### TAXES

Any and all sales, manufacturers' taxes and/or other charges levied or imposed by any governmental authority, foreign or domestic, upon any merchandise sold or contacted to be sold shall be paid by Customer and added to the purchase price unless satisfactory and appropriate tax exception certificates are supplied to the Seller.

### OVERDUE INVOICES

Interest charged at a rate of 1.5% per month on all overdue invoices.

### FREIGHT

\$4000.00 net for prepaid freight.

All shipments are F.O.B. seller's factory or authorized warehouse.

Prepaid orders will be shipped via the most economical route of our choice. If the Customer selects a route with a higher rate, the difference will be charged to the Customer.

### SHIPPING RESPONSIBILITY

Canplas' responsibility ceases when the carrier signs for the shipment in good order. We cannot be responsible for loss or damage to goods in transit, or delays or carriers in delivering shipments or for damages resulting from such delays as those caused by fire, explosion, act of God, strike or other difference with workmen, shortage of material or labor, delays in transportation, government restrictions, war, riot, civil

commotion or cause beyond our control. Where shortage or damage is apparent, details should be noted by the carrier on the freight bill at the time of delivery. In case of concealed damage, carrier should be called at once to inspect the damaged shipment. Do not return damaged goods.

### RETURNED GOODS

A Returned Goods Authorization Form issued by Canplas must accompany goods which are returned. We reserve the right to refuse the return of any item that is not a regular stock item with Canplas. On items that are acceptable for credit, a restocking charge of twenty-five percent (25%) will be assessed against the credit to cover our handling, and/or inspecting or repackaging. Freight on returned goods will be the responsibility of the customer unless the reason for the return is due to defective goods. All goods returned must be in a saleable condition.

### WARRANTY

Seller's products are carefully inspected for manufacturing defects, however, it is not always possible to detect hidden defects. Said products are warranted only to the extent that Seller will replace without charge, products proven to have manufacturing defects within 6 months of the date of delivery thereof and provided Seller has been given an opportunity to inspect the product alleged to be defective and the installation or use thereof. **NO WARRANTY IS INCLUDED AGAINST ANY EXPENSE FOR REMOVAL, REINSTALLATION OR OTHER CONSEQUENTIAL DAMAGES ARISING FROM ANY DEFECT. THE WARRANTIES SET OUT ABOVE ARE THE ONLY WARRANTIES MADE BY SELLER AND ARE EXPRESSLY IN LIEU OF ALL OTHER WARRANTIES, EXPRESSED OR IMPLIED, INCLUDING THE WARRANTIES OF MERCHANTABILITY AND FITNESS FOR A PARTICULAR PURPOSE.**

CANPLAS INDUSTRIES LTD. reserves the right to change the aforementioned TERMS AND CONDITIONS OF SALE without notice.

[www.canplasplumbing.com](http://www.canplasplumbing.com) 1-800-461-5300

#### Head Office, Manufacturing Location and Customer Service Centre

500 VETERANS DRIVE, BOX 1800  
BARRIE, ON L4M 4V3  
CANADA

TELEPHONE: (705) 726-3361  
FAX: (705) 726-2186  
EMAIL: [plumbing@canplas.com](mailto:plumbing@canplas.com)

#### Customer Service Centre and Sales Office

9489 - 200 STREET, UNIT 201  
LANGLEY, B.C. V1M 3A7  
CANADA

TELEPHONE: (604) 455-0432  
FAX: (604) 455-0452

#### Customer Service Centre and Sales Office

11408-163rd STREET  
EDMONTON, AB T5M 3T3  
CANADA

TELEPHONE: (780) 451-3206  
FAX: (780) 452-0536



Mixed Sources  
Product group from well-managed  
forests and other controlled sources  
[www.fsc.org](http://www.fsc.org) Cert no. SGS-COC-006015  
© 1996 Forest Stewardship Council

**canplas®**